



SPECIFICATION FOR LCD MODULE

MODULE NO: YB-TG1280800S06B-N-A0

Doc.Version:03

Customer Approval:

<input type="checkbox"/> Accept	<input type="checkbox"/> Reject
---------------------------------	---------------------------------

YEEBO	NAME	SIGNATURE	DATE
Prepare	Electronic Engineer	張景璋	2015.11.3
Check	Mechanical Engineer	何景倫	2015.11.3
Verify		蔡志凱	2015.11.7
Approval		陳志仁	2015.11.3

APPROVAL FOR SPECIFICATIONS ONLY

APPROVAL FOR SPECIFICATIONS AND SAMPLE

WIMRD005-02-C



1. Revision History

Sample Version	DOC. Version	DATE	DESCRIPTION		CHANGED BY
A0	00	2014-12-15	FULL SPEC	First issue	Fanny / Jimmy
A0	01	2014-12-16	FULL SPEC	ADD LED Lifetime TYP Value	Fanny / Jimmy
A0	02	2015-03-16	FULL SPEC	First Sample	Fanny / Jimmy
A0	03	2015-11-03	FULL SPEC	Add NTSC.....P.11	Fanny / Jimmy



2. Table of Contents:

NO	CONTENTS	PAGE
1	Revision History	1
2	Table of Contents	2
3	Module Numbering System	3
4	General Specification	4
5	LCM drawing	5
6	Electrical Characteristics	6
7	Optical Characteristics	11
8	Interface Pin Assignment	13
9	Backlight Characteristics	15
10	Standard Specification for Reliability	16
11	Specification of Quality Assurance	18
12	Handling Precaution	26
13	Guarantee	26



3. Module Numbering System:

(Example)

YB-TG240320S01D-T-A0

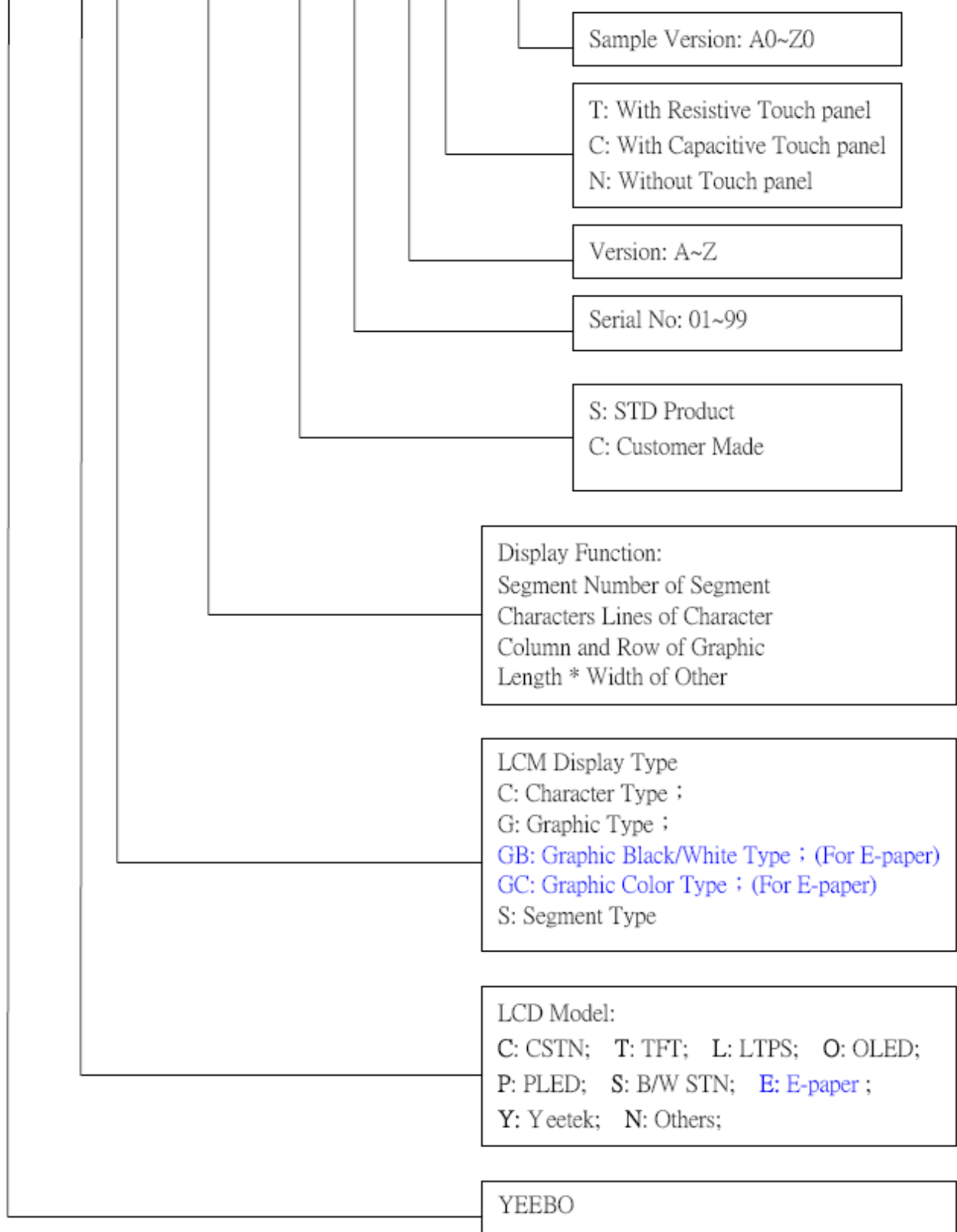



4. General Specification:

ITEM	CONTENTS
Module Size	229.46(W) * 149.1(H) * 2.5(T) mm
Module Size(With PCB)	229.46(W) * 149.1 (H) * 4.56 (T) mm
Display Size(Diagonal)	10.1 inch
Display Format	1280(RGB) * 800 Pixels
Active Area	216.96(W) * 135.6(H) mm
Pixel Pitch	0.1695 * 0.1695 mm
LCD Type	TFT(16.7M) / Transmissive / Normal Black / Glare
View Direction	Free
Interface	LVDS
Weight	190g



5. LCM drawing:

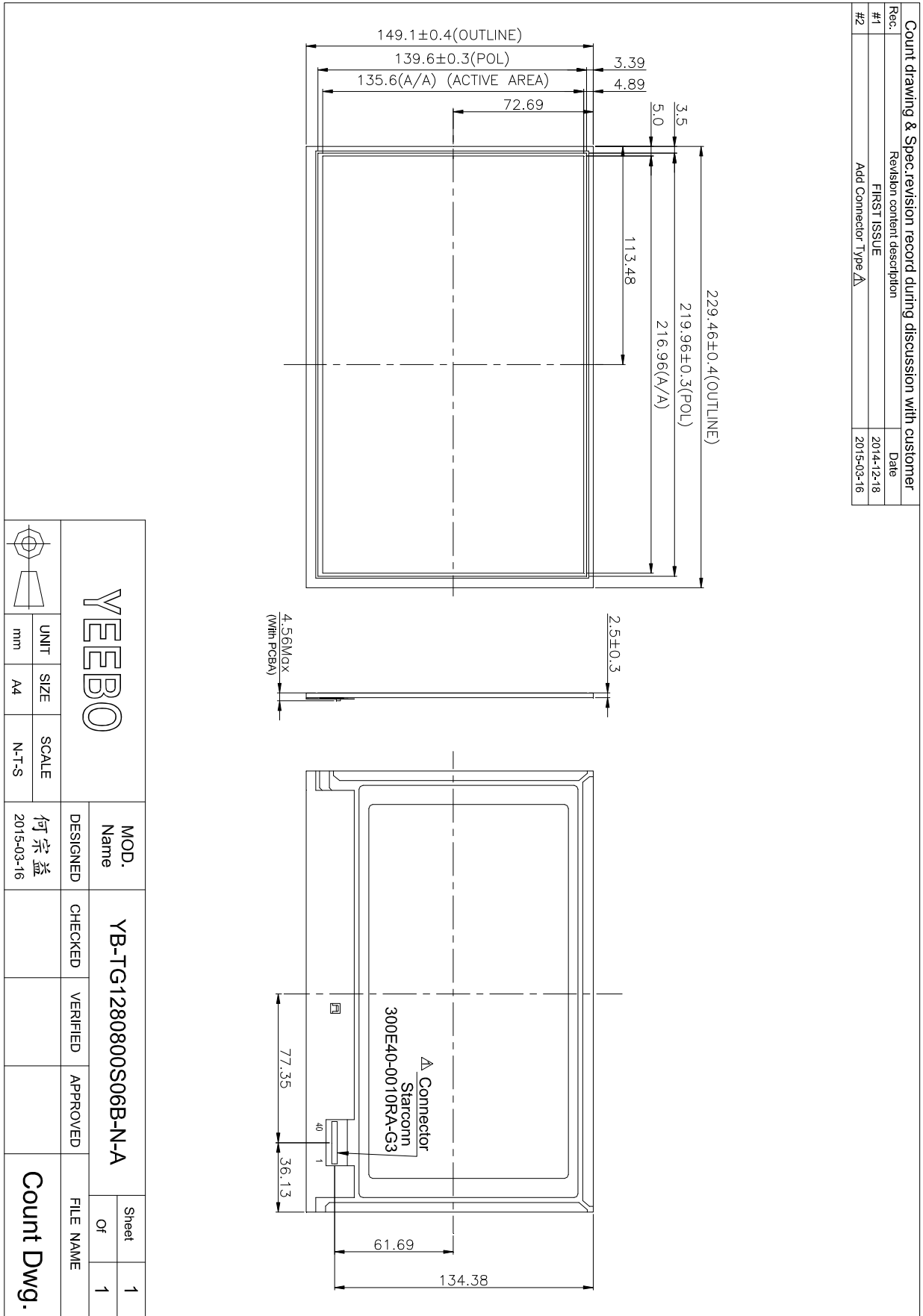



6. Electrical Characteristics

6-1 Absolute Maximum Ratings

(Ta=25°C VSS=0V)

Item	Symbol	Min.	Type	Max.	Unit	Remark
Power Supply voltage	VDD	-0.3	-	7.0	Volt	
	VLED	-0.3	-	24.0	Volt	
Operating Temperature	Topr	-20	-	+70	°C	
Operating Humidity	Hopr	10		+90	%RH	(1)(2)(3)
Storage Temperature	Tstg	-30	-	+80	°C	
Storage Humidity	Hstg	10		+90	%RH	

Note :

- (1) Maximum Wet-Bulb temperature should be 39 degree C and no condensation.
- (2) When you apply the LCD module for OA system. Please make sure to keep the temperature of LCD module is less than 70°C
- (3) Storage / Operating temperature

6-2 Operating Conditions

($T_a=25^{\circ}\text{C}$)

Item	Symbol	Min.	Typ.	Max.	Unit	Remark
Power Supply voltage	VDD	3.0	3.3	3.6	Volt	
Power Supply Current	IDD	-	270	-	mA	
LCD Ripple Voltage	VDDrp	-	-	300	mV	

6-3 LVDS Receiver

6-3-1 Signal Electrical Characteristics For LVDS Receiver

Parameter	Symbol	Min.	Typ.	Max.	Unit	Conditions
Differential Input High	Vth	-	-	+100	mV	$V_{CM}=1.2\text{V}$
Differential Input Low	Vtl	-100	-	-	mV	$V_{CM}=1.2\text{V}$
Magnitude Differential Input	V_{ID}	200	-	400	mV	-
Common Mode Voltage	V_{CM}	$0.3+(V_{ID}/2)$	-	$V_{DD}-1.2-(V_{ID}/2)$	V	-
Common Mode Voltage	ΔV_{CM}	-	-	50	mA	$V_{CM}=1.2\text{V}$

Note

- (1) Input signals shall be low or Hi-Z state when VDD is off.
- (2) All electrical characteristics for LVDS signal are defined and shall be measured at the interface connector of LCD.

Voltage Definitions

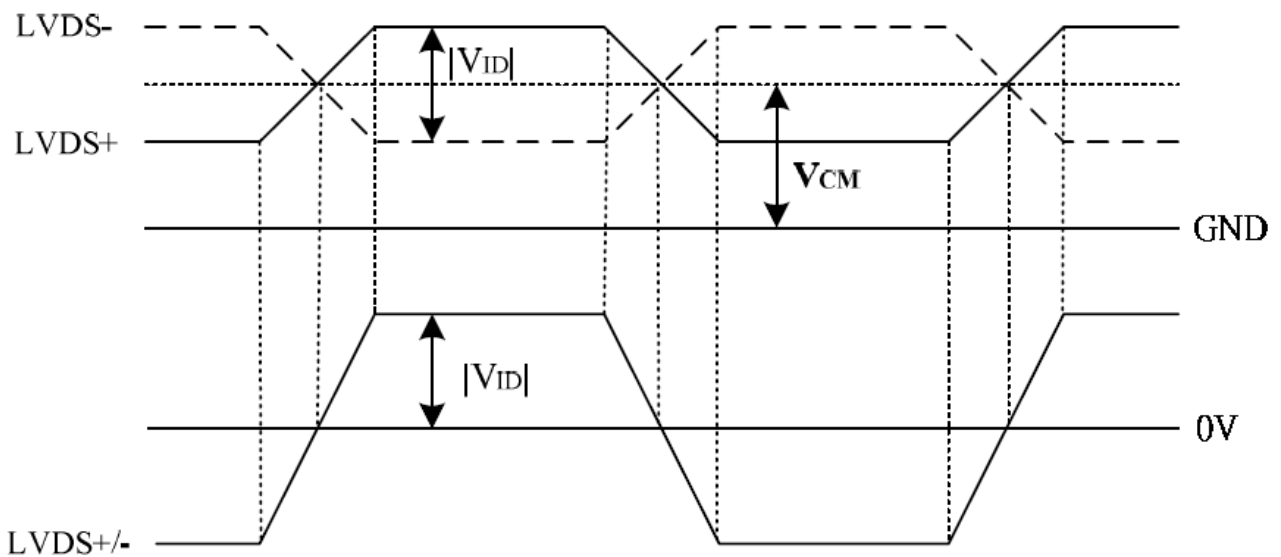

LVDS Data Mapping

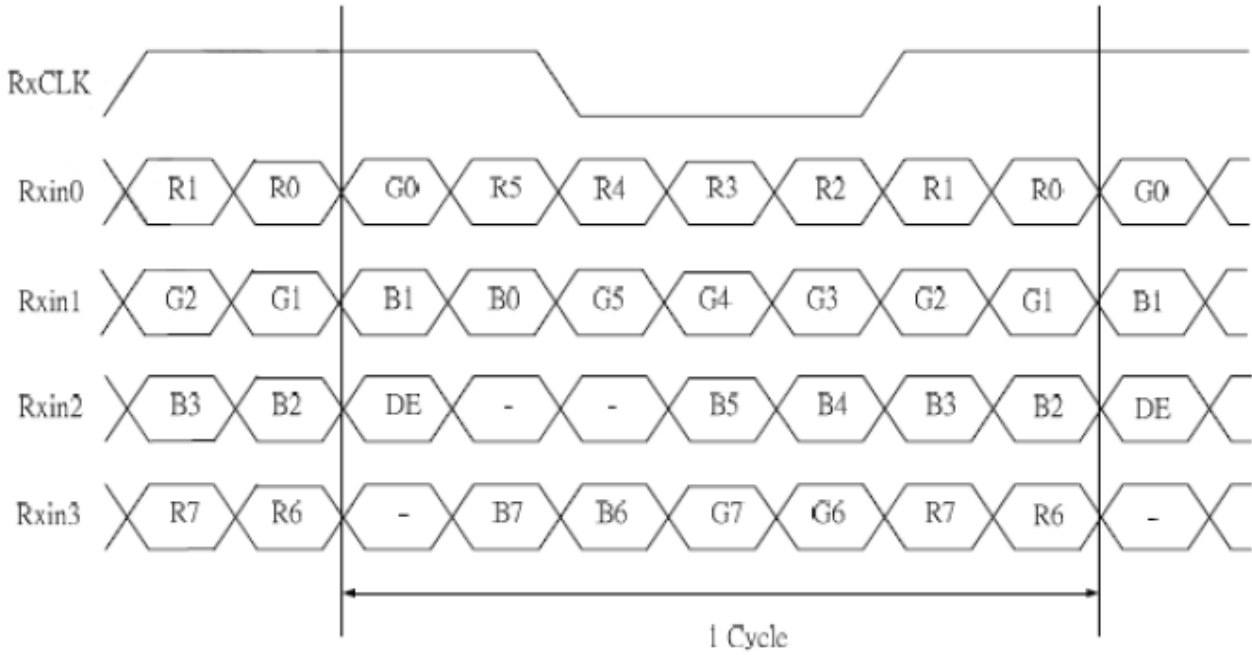

6-4 Interface Timing

6-4-1 Timing Characteristics

Interface Timings

Parameter	Symbol	Unit	Min.	Typ.	Max.
Frame Rate	--	Hz	-	60	-
Frame Period	tV	line	(815)	(823)	(1023)
Vertical Display Time	tVD	line	800		
Vertical Blanking Time	tVW+tVBP+tVFP	line	(15)	(23)	(33)
1 Line Scanning Time	tH	clock	(1410)	(1440)	(1470)
Horizontal Display Time	tHD	clock	1280		
Horizontal Blanking Time	tHW+tHBP+tHFP	clock	(60)	(160)	(190)
Clock Rate	1/TC	MHz	(68.9)	(71.1)	(73.4)

6-4-2 Timing Diagram of Interface Signal(DE mode)

Timing Characteristics

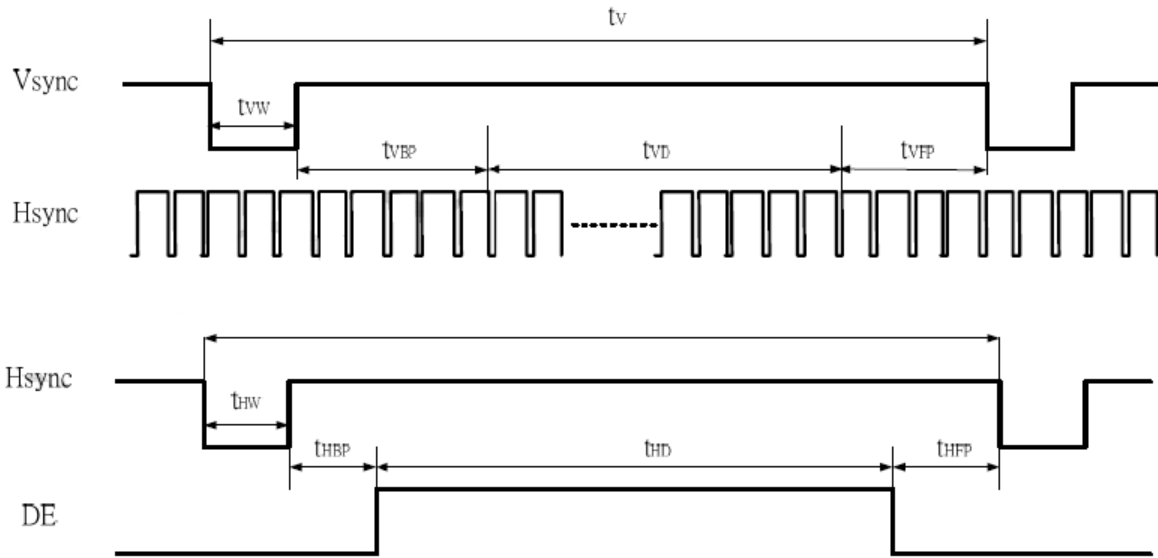

6-5 Power ON/OFF Sequence

Power on/off sequence is as follows. Interface signals are also shown in the chart. Signals from any system shall be Hi-Z state or low level when VDD is off.

Power Sequence

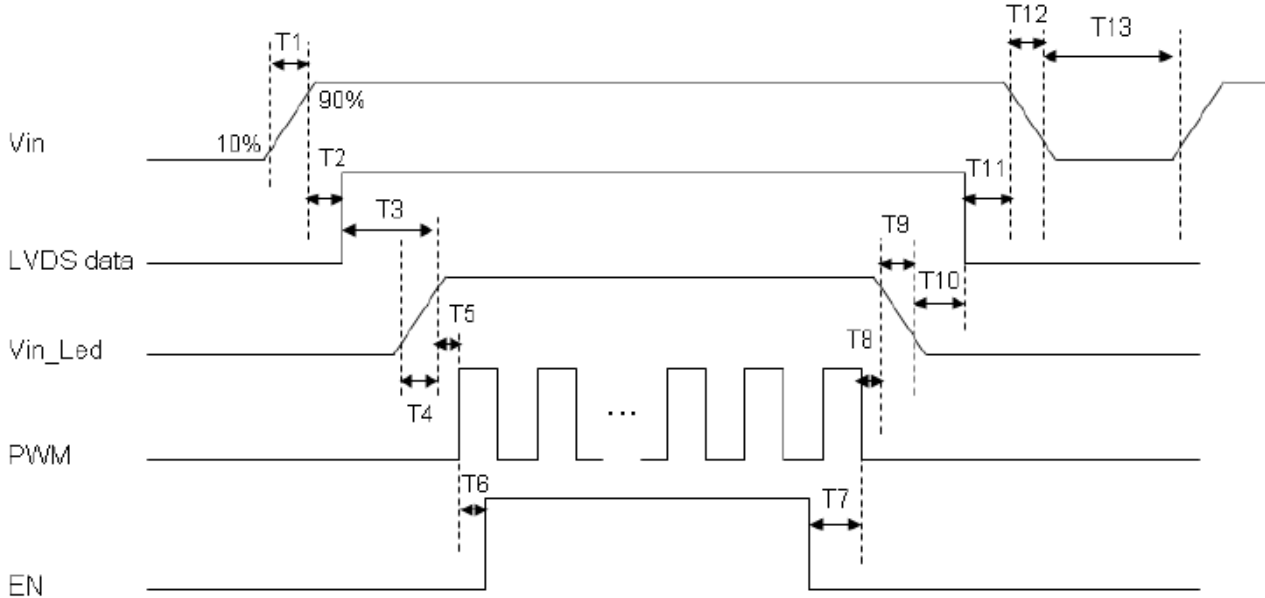

Power Sequencing Requirements

Parameter	Symbol	Unit	Min	Typ.	Max
VIN Rise Time	T1	ms	0.5	--	10
VIN Good to Signal Valid	T2	ms	30	--	90
Signal Valid to Backlight On	T3	ms	200	--	--
Backlight Power On Time	T4	ms	0.5	--	--
Backlight VDD Good to System PWM On	T5	ms	10	--	--
System PWM ON to Backlight Enable ON	T6	ms	10	--	--
Backlight Enable Off to System PWM Off	T7	ms	0	--	--
System PWM Off to B/L Power Disable	T8	ms	10	--	--
Backlight Power Off Time	T9	ms	0.5	10	30
Backlight Off to Signal Disable	T10	ms	200	--	--
Signal Disable to Power Down	T11	ms	0	--	50
VIN Fall Time	T12	ms	0.5	10	30
Power Off	T13	ms	500	--	--



7. Optical Characteristics:

Item	Symbol	Conditions	Specifications			Unit	Remark	
			Min	Typ	Max			
Contrast Ratio	CR	Normal $\theta = \Phi = 0^\circ$	600	800	-		Note 3	
Response time	Rising +Falling				25	50	ms	Note 2
NTSC	-	-	-	45	-	%	Note 1	
Viewing angle (CR \geq 10) B/L ON	Hor.	θ_L	$\Phi = 180^\circ$ (9 o'clock)	75	85	-	deg.	Note 1
		θ_R	$\Phi = 0^\circ$ (3 o'clock)	75	85	-		
	Ver.	θ_T	$\Phi = 90^\circ$ (12 o'clock)	75	85	-		
		θ_B	$\Phi = 270^\circ$ (6 o'clock)	75	85	-		

Measuring Condition

1. Measuring surrounding: dark room
2. Ambient temperature: $25 \pm 2^\circ\text{C}$
3. 30 min. Warm-up time.

Color of CIE Coordinate:

Item	Symbol	Min.	Typ.	Max.	
Chromaticity Coordinates (Transmissive)	Red	x	0.511	0.561	0.611
		y	0.284	0.334	0.384
	Green	x	0.291	0.341	0.391
		y	0.518	0.568	0.618
	Blue	x	0.111	0.161	0.211
		y	0.079	0.129	0.179
	White	x	0.263	0.313	0.363
		y	0.279	0.329	0.379

Note 1: Definition of viewing angle range

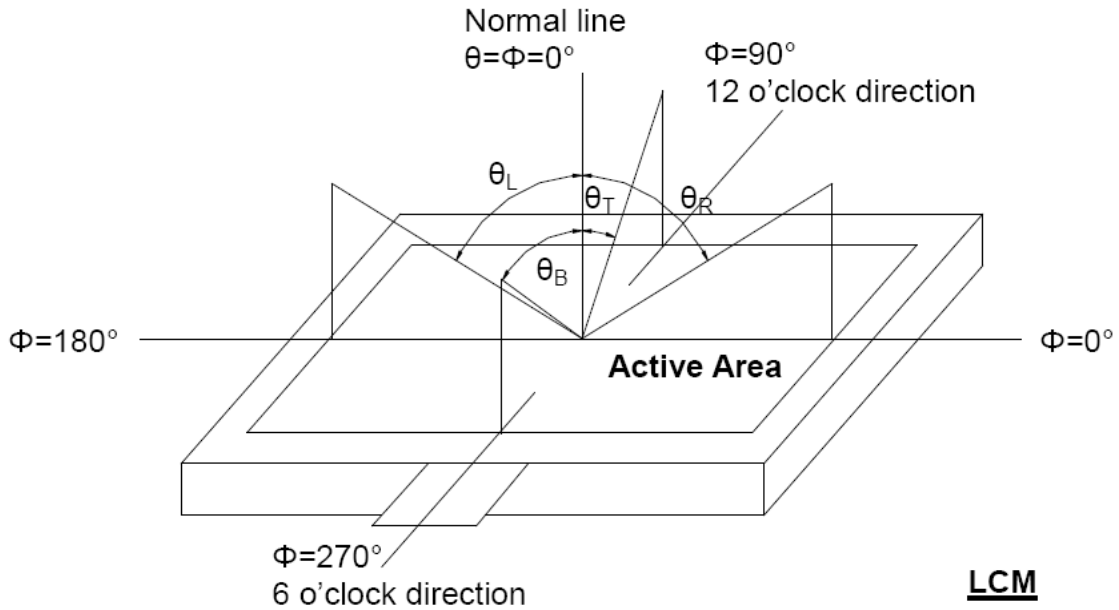

Note 2 :

Definition of Response Time

The response time is defined as the LCD optical switching time interval between “White” state and “Black” state. Rise time (TON) is the time between photo detector output intensity changed from 90% to 10%. And fall time (TOFF) is the time between photo detector output intensity changed from 10% to 90%.

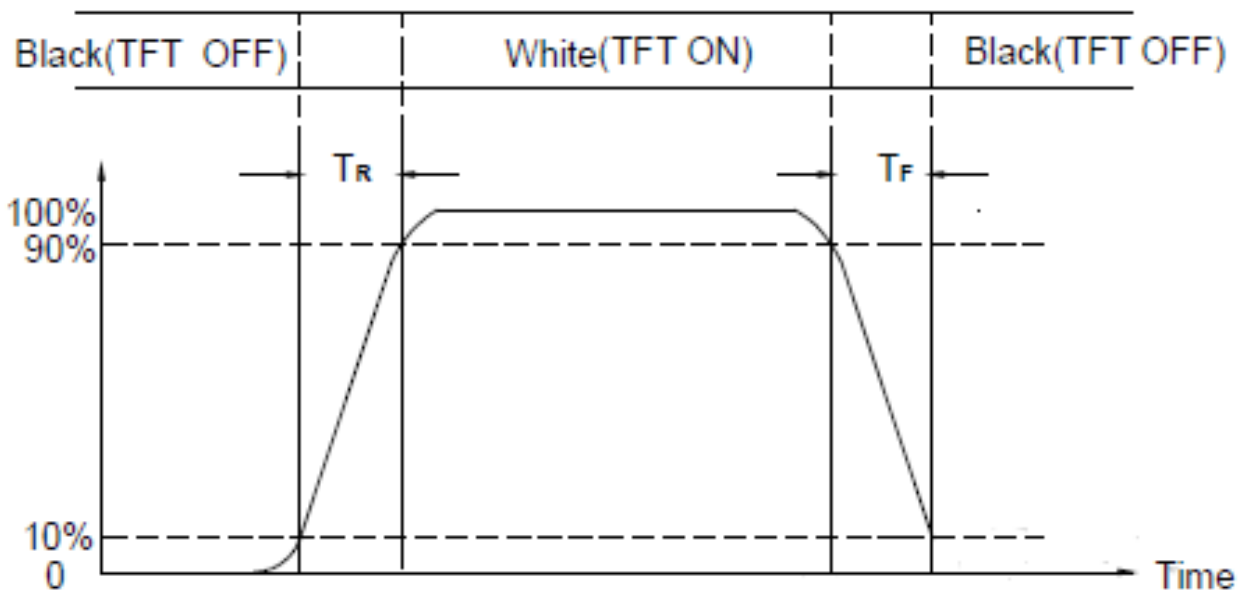

Note 3 :

Definition of contrast ratio

$$\text{Contrast ratio (CR)} = \frac{\text{Luminance measured when LCD on the "White" state}}{\text{Luminance measured when LCD on the "Black" state}}$$



8. Interface Pin Assignment:

8-1 LCM FPC Interface

No.	Symbol	I/O	Function	Remark
1	NC	---	No Connection.	
2	VDD	P	Power Voltage.	
3	VDD	P	Power Voltage.	
4	NC	---	Internal testing pin. (No Connection)	
5	NC	---	Internal testing pin. (No Connection)	
6	NC	---	Internal testing pin. (No Connection)	
7	NC	---	No Connection	
8	RXIN0-	I	-LVDS differential data input	
9	RXIN0+	I	+LVDS differential data input	
10	GND	P	Ground	
11	RXIN1-	I	-LVDS differential data input	
12	RXIN1+	I	+LVDS differential data input	
13	GND	P	Ground	
14	RXIN2-	I	-LVDS differential data input	
15	RXIN2+	I	+LVDS differential data input	
16	GND	P	Ground	
17	RXCLKIN-	I	-LVDS differential clock input	
18	RXCLKIN+	I	+LVDS differential clock input	
19	GND	P	Ground	
20	RXIN3-	I	-LVDS differential data input	
21	RXIN3+	I	+LVDS differential data input	
22	GND	P	Ground	
23	LED-	P	Ground for LED Driving	
24	LED-	P	Ground for LED Driving	
25	LED-	P	Ground for LED Driving	
26	NC	---	No Connection	
27	LED_PWM	P	PWM Input Signal for LED Driver	
28	LED_EN	P	LED Enable Pin	
29	NC	---	Reserved For CABC (No Connection)	
30	NC	---	No Connection	



No.	Symbol	I/O	Function	Remark
31	LED+	P	Power Supply for LED Driver	
32	LED+	P	Power Supply for LED Driver	
33	LED+	P	Power Supply for LED Driver	
34	NC	---	No Connection	
35	NC	---	Internal testing pin. (No Connection)	
36	NC	---	No Connection	
37	NC	---	No Connection	
38	NC	---	No Connection	
39	NC	---	No Connection	
40	NC	---	No Connection	

I: input, O: output, P: Power

Note: All input signals shall be low or Hi- resistance state when VDD is off.

9. Backlight Characteristics:

9-1 LED driver Input and Output Specification

(Ta=25°C)

Item	Symbol	Min.	Typ.	Max.	Unit	Note	
LED input Voltage	V_LED	(6)	(12)	(21)	V	1	
LED Power Consumption	P_LED	-	-	(2.5)	W	1	
LED Forward Voltage	V _F	(2.9)	-	(3.2)	V	1	
LED Forward Current	I _F	-	(20)	-	mA		
PWM Signal Voltage	V _{PWM_EN}	High	(3.0)	-	(3.6)		V
		Low	(0)	-	(0.4)		
LED Enable Voltage	V _{LED_EN}	High	(3.0)	-	(3.6)	V	
		Low	(0)	-	(0.4)		
Input PWM Frequency	FPWM	(1)	-	(2)	KHz	DDIM≥1% (1)	
		(2)	-	(5)		DDIM≥2.5% (1)	
		(5)	-	(10)		DDIM≥5% (1)	
		(10)	-	(20)		DDIM≥10% (1)	
Luminous Intensity for LCM	I _v	300	350	-	cd/m ²	2	
Uniformity for LCM	-	70	-	-	%	3	
Life Time	-	-	50000	-	Hr.	4	

NOTE:

1. Operating temperature 25°C , humidity 50%.
2. Average Luminous Intensity of P1-P13
3. Uniformity = Min/Max * 100%
4. LED life time defined as follows: The final brightness is at 50% of original brightness

Measured Method: (X*Y: Light Area)

TEST POINT

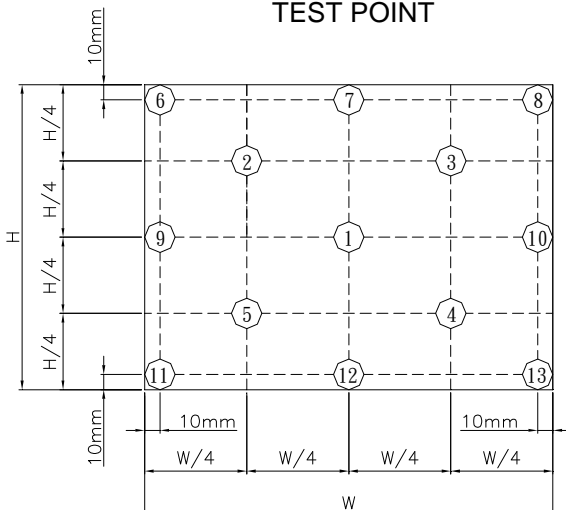

10. Standard Specification for Reliability .:

10-1. Standard Specifications for Reliability of LCD Module

No	Item	Description
01	High temperature operation	The sample should be allowed to stand at 70°C for 120 hours under driving condition and then returning it to normal temperature condition, and allowing it stand for 2 hours.
02	Low temperature operation	The sample should be allowed to stand at -20°C for 120 hours under driving condition and then returning it to normal temperature condition, and allowing it stand for 2 hours.
03	High temperature storage	The sample should be allowed to stand at 80°C for 240 hours under no-load condition, and then returning it to normal temperature condition, and allowing it stand for 2 hours.
04	Low temperature storage	The sample should be allowed to stand at -30°C for 240 hours under no-load condition, then returning it to normal temperature condition, and allowing it stand for 2 hours.
05	Moisture storage	The sample should be allowed to stand at 60°C, 90%RH MAX for 240 hours under no-load condition, then taking it out and drying it at normal temperature for 2 hours.
06	Thermal shock storage	The sample should be allowed to stand the following 10 cycles : -20°C for 30 minutes → normal temperature for 5 minutes → +60°C for 30 minutes → normal temperature for 5 minutes, as one cycle.
07	Packing vibration	Frequency range : 10Hz ~ 55Hz Amplitude of vibration : 1.5mm Sweep time: 12 min X, Y, Z 2 hours for each direction.
08	Packing drop test	According to ISTA 1A 2001.
09	Electrical Static Discharge	Air: ±6KV 150pF/330Ω 5 times
		Contact: ±4KV 150pF/330Ω 5 time

*Sample size for each test item is 3~5pcs



10 - 2. Testing Conditions and Inspection Criteria

For the final test the testing sample must be stored at room temperature for 24 hours, after the tests listed in Table 10.2, Standard specifications for Reliability have been executed in order to ensure stability.

No	Item	Test Model	In section Criteria
01	Current Consumption	Refer To Specification	The current consumption should conform to the product specification.
02	Contrast	Refer To Specification	After the tests have been executed, the contrast must be larger than half of its initial value prior to the tests.
03	Appearance	Visual inspection	Defect free.

10- 3. MTBF

MTBF	Functions, performance, appearance, etc. shall be free from remarkable deterioration within 50,000 hours under ordinary operating and storage conditions room temperature ($25\pm 5^{\circ}\text{C}$), normal humidity ($50\pm 10\%$ RH), and in area not exposed to direct sun light.
------	---



11. Specification of Quality Assurance:

11-1. Purpose

This standard for Quality Assurance should affirm the quality of LCD module products to supply to purchaser by YEEBO CORPORATION (Supplier).

11-2. Standard for Quality Test

a. Inspection:

Before delivering, the supplier should take the following tests, and affirm the quality of product.

b. Electro-Optical Characteristics:

According to the individual specification to test the product.

c. Test of Appearance Characteristics:

According to the individual specification to test the product.

d. Test of Reliability Characteristics:

According to the definition of reliability on the specification for testing products.

e. Delivery Test:

Before delivering, the supplier should take the delivery test.

(i) Test method: According to MIL-STD105E.General Inspection Level II take a single time.

(ii) The defects classify of AQL as following:

Major defect: AQL = 0.65%

Minor defect: AQL = 2.5%

Total defects: AQL = 2.5%

11-3. Non- conforming Analysis & Deal With Manners

a. Non- conforming Analysis:

(i) Purchaser should supply the detail data of non- conforming sample and the non- conforming.

(ii) After accepting the detail data from purchaser, the analysis of non- conforming should be finished in two weeks.

(iii) If supplier can not finish analysis on time, must announce purchaser before 3 days.

b. Disposition of non- conforming:

(i) If find any product defect of supplier during assembly time, supplier must change the good product for every defect after recognition.

(ii) Both supplier and customer should analyze the reason and discuss the disposition of non- conforming when the reason of nonconforming is not sure.

11-4. Agreement items

Both sides should discuss together when the following problems happen.

a. There is any problem of standard of quality assurance, and both sides should think that must be modified.

b. There is any argument item which does not record in the standard of quality assurance.

c. Any other special problem.

11-5. Standard of The Product Appearance Test

a. Manner of appearance test:

(i) The test must be under 20W × 2 or 40W fluorescent light, and the distance of view must be at 30±5cm.

(ii) When test the model of transmissive product must add the reflective plate.

(iii) The test direction is base on around 10° of vertical line.

(iiii) Temperature: 25±5°C Humidity: 60±10%RH

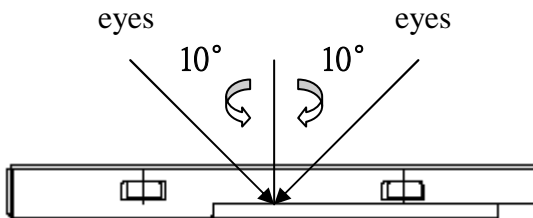

(iv) Definition of area:

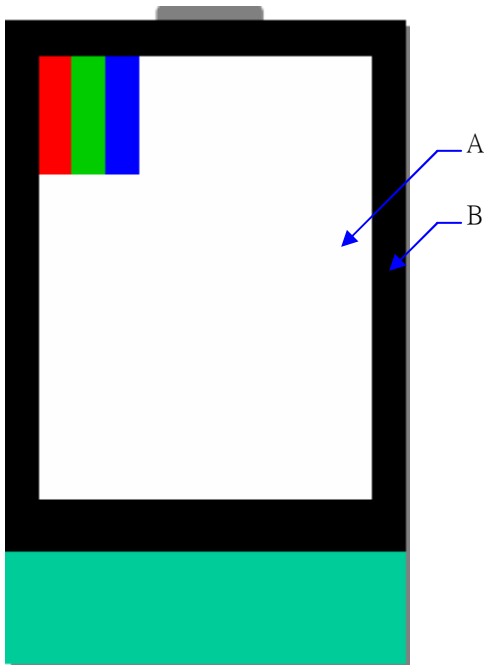

A. Area: Viewing area.

B. Area: Out of viewing area.

(Outside viewing area)

b. Basic principle:

(i) It will accord to the AQL when the standard can not be described.

(ii) The sample of the lowest acceptable quality level must be discussed by both supplier and customer when any dispute happened.

(iii) Must add new item on time when it is necessary.

c. Standard of inspection: (Unit: mm)

11-6. Inspection specification

Defect out of viewing area can be neglected.

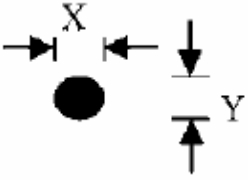
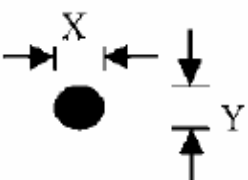
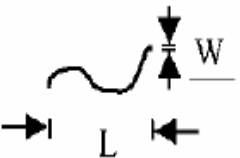
NO	Item	Criterion	AQL													
01	Electrical Testing	1.1 Missing vertical, horizontal segment, segment contrast defect. 1.2 Missing character, dot or icon. 1.3 Display malfunction. 1.4 No function or no display. 1.5 Current consumption exceeds product specifications. 1.6 LCD viewing angle defect. 1.7 Mixed product types. 1.8 Flicker	0.65													
02	Black or White spots or Bright spots or Color spots on LCD (Display only)	2.1 Dot dimension as below drawing: $\Phi = (X+Y) / 2$  <table border="1" data-bbox="813 772 1348 936"> <thead> <tr> <th>Size(mm)</th> <th>Acceptable Q'ty</th> </tr> </thead> <tbody> <tr> <td>$\Phi \leq 0.20$</td> <td>Accept no dense</td> </tr> <tr> <td>$0.20 < \Phi \leq 0.50$</td> <td>5</td> </tr> <tr> <td>$0.50 < \Phi$</td> <td>0</td> </tr> </tbody> </table> <p style="text-align: right;">* Densely spaced: No more than two spots within 3mm.</p>	Size(mm)	Acceptable Q'ty	$\Phi \leq 0.20$	Accept no dense	$0.20 < \Phi \leq 0.50$	5	$0.50 < \Phi$	0	2.5					
Size(mm)	Acceptable Q'ty															
$\Phi \leq 0.20$	Accept no dense															
$0.20 < \Phi \leq 0.50$	5															
$0.50 < \Phi$	0															
03	LCD and Touch Panel black spots, white spots, contamination (non – display)	3.1 Round type: As following drawing $\Phi = (X+Y) / 2$  <table border="1" data-bbox="813 1160 1348 1323"> <thead> <tr> <th>Size(mm)</th> <th>Acceptable Q'ty</th> </tr> </thead> <tbody> <tr> <td>$\Phi \leq 0.20$</td> <td>Accept no dense</td> </tr> <tr> <td>$0.20 < \Phi \leq 0.50$</td> <td>5</td> </tr> <tr> <td>$0.50 < \Phi$</td> <td>0</td> </tr> </tbody> </table> <p style="text-align: right;">* Densely spaced: No more than two spots within 3mm.</p>	Size(mm)	Acceptable Q'ty	$\Phi \leq 0.20$	Accept no dense	$0.20 < \Phi \leq 0.50$	5	$0.50 < \Phi$	0	2.5					
		Size(mm)	Acceptable Q'ty													
$\Phi \leq 0.20$	Accept no dense															
$0.20 < \Phi \leq 0.50$	5															
$0.50 < \Phi$	0															
3.2 Line type: (As following drawing)  <table border="1" data-bbox="718 1525 1348 1856"> <thead> <tr> <th>Length(mm)</th> <th>Width(mm)</th> <th>Acceptable Q'ty</th> </tr> </thead> <tbody> <tr> <td>$L \leq 10$</td> <td>$W \leq 0.1$</td> <td>Accept no dense</td> </tr> <tr> <td>$L \leq 10.0$</td> <td>$0.1 < W \leq 0.25$</td> <td>4</td> </tr> <tr> <td>$L > 10$</td> <td>----</td> <td>Rejection</td> </tr> <tr> <td>----</td> <td>$0.25 < W$</td> <td>Rejection</td> </tr> </tbody> </table> <p style="text-align: right;">* Densely spaced: No more than two lines within 3mm.</p>	Length(mm)	Width(mm)	Acceptable Q'ty	$L \leq 10$	$W \leq 0.1$	Accept no dense	$L \leq 10.0$	$0.1 < W \leq 0.25$	4	$L > 10$	----	Rejection	----	$0.25 < W$	Rejection	2.5
Length(mm)	Width(mm)	Acceptable Q'ty														
$L \leq 10$	$W \leq 0.1$	Accept no dense														
$L \leq 10.0$	$0.1 < W \leq 0.25$	4														
$L > 10$	----	Rejection														
----	$0.25 < W$	Rejection														

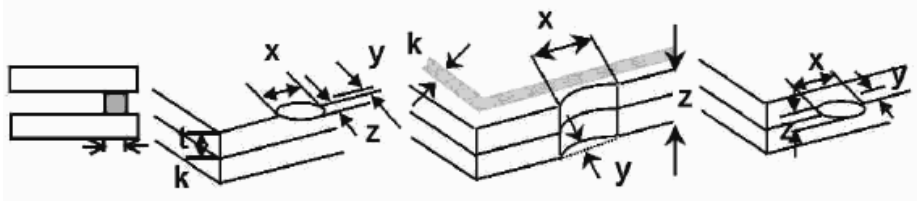
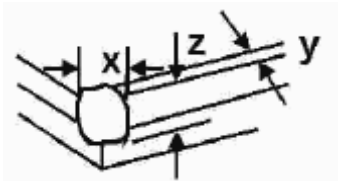
NO	Item	Criterion	AQL																		
04	Polarizer bubbles	<p>If bubbles are visible, judge using black spot specifications, not easy to find, must check in specify direction</p> <table border="1" data-bbox="849 291 1350 533"> <thead> <tr> <th>Size Φ(mm)</th> <th>Acceptable Q'ty</th> </tr> </thead> <tbody> <tr> <td>$\Phi \leq 0.20$</td> <td>Accept no dense</td> </tr> <tr> <td>$0.20 < \Phi \leq 0.50$</td> <td>4</td> </tr> <tr> <td>$0.50 < \Phi \leq 1.00$</td> <td>3</td> </tr> <tr> <td>$1.00 < \Phi$</td> <td>0</td> </tr> <tr> <td>Total Q'ty</td> <td>4</td> </tr> </tbody> </table>	Size Φ (mm)	Acceptable Q'ty	$\Phi \leq 0.20$	Accept no dense	$0.20 < \Phi \leq 0.50$	4	$0.50 < \Phi \leq 1.00$	3	$1.00 < \Phi$	0	Total Q'ty	4	2.5						
Size Φ (mm)	Acceptable Q'ty																				
$\Phi \leq 0.20$	Accept no dense																				
$0.20 < \Phi \leq 0.50$	4																				
$0.50 < \Phi \leq 1.00$	3																				
$1.00 < \Phi$	0																				
Total Q'ty	4																				
05	Scratches	Follow NO.3 -2 Line Type.																			
06	Chipped glass	<p>Symbols: x: Chip length y: Chip width z: Chip thickness k: Seal width t: Glass thickness a: LCD side length L: Electrode pad length</p> <p>6.1 General glass chip: 6.1.1 Chip on panel surface and crack between panels:</p>  <table border="1" data-bbox="395 1019 1220 1176"> <thead> <tr> <th>z: Chip thickness</th> <th>y: Chip width</th> <th>x: Chip length</th> </tr> </thead> <tbody> <tr> <td>$Z \leq 1/2t$</td> <td>Not over viewing area</td> <td>$x \leq 1/8a$</td> </tr> <tr> <td>$1/2t < z \leq 2t$</td> <td>Not exceed 1/3k</td> <td>$x \leq 1/8a$</td> </tr> </tbody> </table> <p>⊙ Unit: mm ⊙ If there are 2 or more chips, x is the total length of each chip</p> <p>6.1.2 Corner crack:</p>  <table border="1" data-bbox="395 1534 1220 1691"> <thead> <tr> <th>z: Chip thickness</th> <th>y: Chip width</th> <th>x: Chip length</th> </tr> </thead> <tbody> <tr> <td>$Z \leq 1/2t$</td> <td>Not over viewing area</td> <td>$x \leq 1/8a$</td> </tr> <tr> <td>$1/2t < z \leq 2t$</td> <td>Not exceed 1/3k</td> <td>$x \leq 1/8a$</td> </tr> </tbody> </table> <p>⊙ Unit: mm ⊙ If there are 2 or more chips, x is the total length of each chip</p>	z: Chip thickness	y: Chip width	x: Chip length	$Z \leq 1/2t$	Not over viewing area	$x \leq 1/8a$	$1/2t < z \leq 2t$	Not exceed 1/3k	$x \leq 1/8a$	z: Chip thickness	y: Chip width	x: Chip length	$Z \leq 1/2t$	Not over viewing area	$x \leq 1/8a$	$1/2t < z \leq 2t$	Not exceed 1/3k	$x \leq 1/8a$	2.5
z: Chip thickness	y: Chip width	x: Chip length																			
$Z \leq 1/2t$	Not over viewing area	$x \leq 1/8a$																			
$1/2t < z \leq 2t$	Not exceed 1/3k	$x \leq 1/8a$																			
z: Chip thickness	y: Chip width	x: Chip length																			
$Z \leq 1/2t$	Not over viewing area	$x \leq 1/8a$																			
$1/2t < z \leq 2t$	Not exceed 1/3k	$x \leq 1/8a$																			

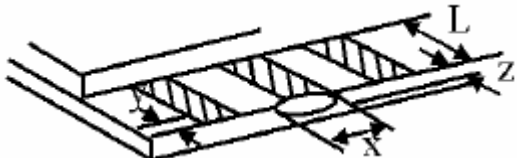
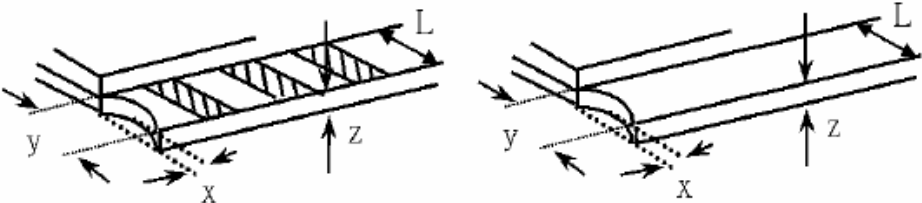
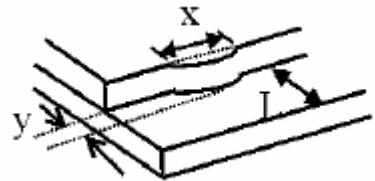
NO	Item	Criterion	AQL																
07	Glass crack	<p>Symbols: x: Chip length y: Chip width z: Chip thickness k: Seal width t: Glass thickness a: LCD side length L: Electrode pad length</p> <p>7.2 Protrusion over terminal: 7.2.1 Chip on electrode pad:</p>  <table border="1" data-bbox="539 683 1225 840"> <tr> <td>y: Chip width</td> <td>x: Chip length</td> <td>z: Chip thickness</td> </tr> <tr> <td>$y \leq 0.5\text{mm}$</td> <td>$x \leq 1/8a$</td> <td>$0 < z \leq t$</td> </tr> </table> <p>7.2.2 Non-conductive portion:</p>  <table border="1" data-bbox="539 1198 1225 1355"> <tr> <td>y: Chip width</td> <td>x: Chip length</td> <td>z: Chip thickness</td> </tr> <tr> <td>$y \leq L$</td> <td>$x \leq 1/8a$</td> <td>$0 < z \leq t$</td> </tr> </table> <p>⊙ If there chipped area touches the ITO terminal, over 2/3 of the ITO must remain and be inspected according to electrode terminal specifications. ⊙ If the product will be heat sealed by the customer, the alignment mark must not be damaged.</p> <p>7.2.3 Substrate protuberance and internal crack</p>  <table border="1" data-bbox="858 1668 1300 1825"> <tr> <td>y: width</td> <td>x: length</td> </tr> <tr> <td>$y \leq 1/3L$</td> <td>$X \leq a$</td> </tr> </table>	y: Chip width	x: Chip length	z: Chip thickness	$y \leq 0.5\text{mm}$	$x \leq 1/8a$	$0 < z \leq t$	y: Chip width	x: Chip length	z: Chip thickness	$y \leq L$	$x \leq 1/8a$	$0 < z \leq t$	y: width	x: length	$y \leq 1/3L$	$X \leq a$	2.5
y: Chip width	x: Chip length	z: Chip thickness																	
$y \leq 0.5\text{mm}$	$x \leq 1/8a$	$0 < z \leq t$																	
y: Chip width	x: Chip length	z: Chip thickness																	
$y \leq L$	$x \leq 1/8a$	$0 < z \leq t$																	
y: width	x: length																		
$y \leq 1/3L$	$X \leq a$																		

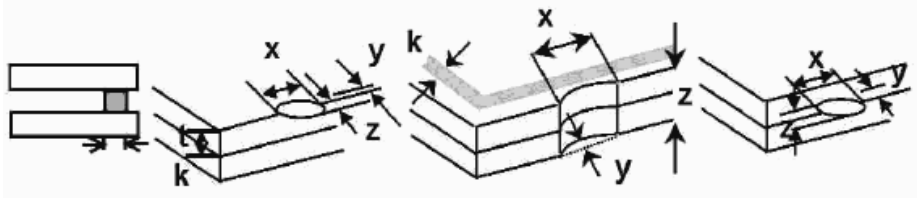
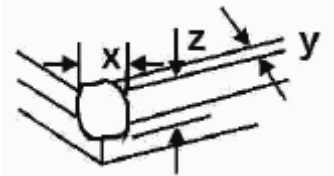

NO	Item	Criterion	AQL
08	Cracked glass	The LCD with extensive crack is not acceptable.	2.5
09	Backlight elements	9.1 Illumination source flickers when lit. 9.2 Spots or scratches that appear when lit must be judged. Using LCD spot, lines and contamination standards. 9.3 Backlight doesn't light or color is wrong.	2.5 2.5 0.65
10	Bezel	Bezel must comply with product specifications.	2.5
11	PCB、COB	11.1 COB seal may not have pinholes larger than 0.2mm or contamination. 11.2 COB seal surface may not have pinholes through to the IC. 11.3 The height of the COB should not exceed the height indicated in the assembly diagram. 11.4 There may not be more than 2mm of sealant outside the seal area on PCB. And there should be no more than three places. 11.5 Parts on PCB must be the same as on the production characteristic chart, There should be no wrong parts, missing parts or excess parts. 11.6 The jumper on the PCB should conform to the product characteristic chart.	2.5 2.5 2.5 2.5 0.65 0.65
12	FPC	12.1 FPC terminal damage \leq 1/2 FPC terminal width and can not affect the function , we judge accept. 12.2 FPC alignment hole damage \leq 1/2 alignment area and can not affect the function , we judge accept.	2.5 2.5
13	Soldering	13.1 No cold solder joints, missing solder connections, oxidation or icicle. 13.2 No short circuits in components on PCB or FPC.	2.5 0.65

NO	Item	Criterion	AQL												
14	Touch Panel Chipped glass	<p>Symbols: x: Chip length y: Chip width z: Chip thickness k: Seal width t: Touch Panel Total thickness a: LCD side length L: Electrode pad length</p> <p>14.1 General glass chip: 14.1.1 Chip on panel surface and crack between panels:</p>  <table border="1" data-bbox="395 801 1217 1019"> <tr> <td>z: Chip thickness</td> <td>y: Chip width</td> <td>x: Chip length</td> </tr> <tr> <td>$Z \leq t$</td> <td>$\leq 1/2 k$ and not over viewing area</td> <td>$x \leq 1/8a$</td> </tr> </table> <p>⊙ Unit: mm ⊙ If there are 2 or more chips, x is the total length of each chip</p> <p>14.1.2 Corner crack:</p>  <table border="1" data-bbox="395 1397 1217 1615"> <tr> <td>z: Chip thickness</td> <td>y: Chip width</td> <td>x: Chip length</td> </tr> <tr> <td>$z \leq t$</td> <td>$\leq 1/2 k$ and not over viewing area</td> <td>$x \leq 1/8a$</td> </tr> </table> <p>⊙ Unit: mm ⊙ If there are 2 or more chips, x is the total length of each chip</p>	z: Chip thickness	y: Chip width	x: Chip length	$Z \leq t$	$\leq 1/2 k$ and not over viewing area	$x \leq 1/8a$	z: Chip thickness	y: Chip width	x: Chip length	$z \leq t$	$\leq 1/2 k$ and not over viewing area	$x \leq 1/8a$	2.5
z: Chip thickness	y: Chip width	x: Chip length													
$Z \leq t$	$\leq 1/2 k$ and not over viewing area	$x \leq 1/8a$													
z: Chip thickness	y: Chip width	x: Chip length													
$z \leq t$	$\leq 1/2 k$ and not over viewing area	$x \leq 1/8a$													

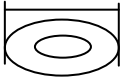
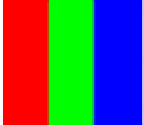
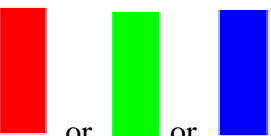
NO	Item	Criterion	AQL						
15	Touch Panel Fish eye	<table border="1"> <tr> <td>SIZE(mm)</td> <td>Acceptable Q'ty</td> </tr> <tr> <td>$L \leq 1.0$</td> <td>Accept no dense</td> </tr> <tr> <td>$L > 1.0\text{mm}$</td> <td>0</td> </tr> </table>	SIZE(mm)	Acceptable Q'ty	$L \leq 1.0$	Accept no dense	$L > 1.0\text{mm}$	0	2.5 
		SIZE(mm)	Acceptable Q'ty						
		$L \leq 1.0$	Accept no dense						
$L > 1.0\text{mm}$	0								
16	Touch Panel Newton ring	Newton ring dimension $\leq 1/2$ touch panel area and not affect font and line distortion ($\leq 2.5\%$), it is acceptable.	2.5						
17	Touch Panel Linearity	Less than 2.5% is acceptable.	2.5						
18	LCD Ripple	Touch the touch panel, cannot see the LCD ripple. Pen: R 1.0mm silicon rubber. Operation Force: 10~100g	2.5						
19	General appearance	19.1 Pin type must match type in specification sheet.	0.65						
		19.2 LCD pin loose or missing pins.	0.65						
		19.3 Product packaging must be the same as specified on packaging specification sheet.	0.65						
		19.4 Product dimension and structure must conform to product specification sheet.	0.65						
20	Definition of Pixel	Pixel : Group of Three Sub-pixels (Red, Green ,Blue):  Dot : Red or Green or Blue  Dot : Any sub-pixel Bright Dot Defects Dots (sub-pixels) on display which is bright in the picture and visible at Black Pattern. Dark Dot Defects Dots(sub-pixels) on display which is dark in the picture and visible at Red/Green/Black/White Pattern. Neighbour Dot Defects Two or three neighbour dots (dot: sub-pixel) cluster(R&G,G&B,B&R,or R&G&B).Dot Defects Inspection Criteria NOTE : Dot out of VA can be ignored.							

Items	Inspection Criteria	
	Details	Allowed quantity
Bright Dot	Not Neighbour Dot	2
Dark Dot	Not Neighbour Dot	3
Total acceptable Qty		5

● Size of dot defect is larger than half of one sub-pixel.

12. Handling Precaution:

12-1 Handling of LCM

- Don't give external shock.
- Don't apply excessive force on the surface.
- Liquid in LCD is hazardous substance. Must not lick and swallow. when the liquid is attach to your hand, skin, cloth etc. Wash it out thoroughly and immediately.
- Don't operate it above the absolute maximum rating.
- Don't disassemble the LCM.
- The operators should be grounded whenever he/she comes into contact with the module. Never touch any of the conductive parts such as the LSI pads, the copper leads on the FPC and the interface terminals with any parts of the human body.
- The modules should be kept in antistatic bags or other containers resistant to static for storage.
- The module is coated with a film to protect the display surface. Be care when peeling off this protective film since static electricity may be generated.

12-2 Storage

- Store in an ambient temperature of $25 \pm 10^{\circ}\text{C}$, and in a relative humidity of $50 \pm 10\% \text{RH}$. Don't expose to sunlight or fluorescent light.
- Storage in a clean environment, free from dust, active gas, and solvent.
- Store in anti-static electricity container.
- Store without any physical load.

12-3 Soldering

- Use only soldering irons with proper grounding and no leakage.
- Iron: No higher than $280 \pm 10^{\circ}\text{C}$ and less than 3 sec during Hand soldering.
- Rewiring: no more than 2 times.

13. Guarantee:

Our products meet requirements of the environment.

YEEBO ROHS requirement is based on European Union Directive 2011/65/EU (ROHS) Requirements and Update.